



PRINCESS CRUISES

FREIGHT SHIPPING INFORMATION

For SUPPLIERS

Revised: January 15, 2010

FREIGHT SHIPPING INFORMATION

Table of Contents

1. Introduction
2. Reference Information for Princess Suppliers
 - A. General Shipping Information
 - B. Marking & Labeling Standards
 - C. Samples of Labeling Methods
 - D. Packing Standards – Labeling Cartons
 - E. Packing Standards – Material on Pallets
 - F. Packing Standards – Cartons to be shipped individually
 - G. Bill of Lading (BOL) and Air Way Bill (AWB) preparation
 - H. Commercial Invoice Preparation
 - I. Hazardous Material
 - J. Delivery of Shipping Documentation
3. “Ship to” Locations
 - A. Consolidation Centers
 - B. Shipments to locations other than Consolidation Centers
4. **Billing Address**

Section 1: Introduction

The purpose of this Freight Shipping Information manual is to provide information for Princess suppliers regarding shipments of materials being purchased for Princess vessels. In addition, it contains ready reference information that can be communicated to transportation companies to instruct them on how to ship, move or deliver our material. Purchase Orders issued by Princess provide the authoritative reference for shipping Princess-purchased material. **REMEMBER: if in doubt, work with the Princess Buyer to clarify information in the Purchase Order.**

Nothing in this guide is intended to provide specific shipping or routing instructions for specific material purchases. Those instructions are contained in the Purchase Order. For shipments of purchased items to a Princess designated distribution center, you will be directed how and where to ship on our Purchase Order. **Please carefully follow the instructions on the Purchase Order and be sure to clarify any shipping uncertainties with the Princess Buyer.**

Section 2: Reference Information for Princess Suppliers

A. General Shipping Information:

Princess Purchase Orders provide the authoritative reference for shipping Princess-purchased material. **Nothing in this guide is intended to provide specific shipping or routing instructions for specific material purchases. Those instructions are contained in the Purchase Order.** For shipments of purchased items to a Princess designated distribution center, you will be directed how and where to ship on our Purchase Order. Please carefully follow the instructions on the Purchase Order and be sure to clarify any shipping uncertainties with the Princess Buyer.

The following are guidelines established by Princess with respect to packing, shipping, storing, and delivering items to Princess receiving locations. These guidelines apply to shipments for all Princess departments and Offices, and are intended as tools for use in logistics planning.

1. When using a shipping company specified by Princess in a Purchase Order, all shipping terms should be “Third Party Prepaid”, and you should indicate on the Bill Of Lading in the “bill to” section any Princess account number that may be supplied to you on the Princess Purchase Order. Also, it is critical to list the approved Princess Purchase Order number in the “customer reference field” on the Bill of Lading.
2. Cash on Delivery (C.O.D.) shipments to Princess will not be accepted.
3. Princess sometimes directs that purchased material be delivered by the supplier to a consolidation center with freight and delivery terms of pre-pay and add (PPA). This may be directed on the Purchase Order, or verbally by the Princess Buyer. When PPA is requested, we ask that you ship with a reputable carrier that you are familiar with and who offers insurance coverage to protect your merchandise while in transit. When shipping PPA, please provide the Princess Buyer with notice of shipment and a tracking number if one is available.
4. The bill of lading and all shipping documents, as well as each package, must contain the name of the Princess vessel, the Princess Purchase Order number, and the onboard department name. This is crucial to identify the shipment, and crucial to timely receipt and payment.

5. Items for different Princess vessels should NEVER be combined or packed in the same box or carton. Keep material for different Princess vessels packed separately.

6. For transportation inside the US only (US to US shipments – not in bond), cartons for different Princess vessels can be combined on one pallet or in one shipment for transportation/shipping purposes only **IF** all the cartons are being sent to the same location. One Bill of Lading or Master Airway Bill for multiple cartons (for US to US shipments only – not in bond) is acceptable as long as the items are not “in bond” and the items for different vessels are NOT COMBINED IN ONE CARTON. The Bill of Lading and commercial invoices for each carton must contain the Purchase Order numbers for every PO contain in that combined shipment.

To clarify, all individual items for one vessel must be packed in one carton separately from material for any other vessel. **DO NOT MIX MATERIAL FOR 2 OR MORE VESSELS IN THE SAME CARTON.** In the US for US to US locations only, multiple cartons for multiple Princess vessels may be combined for transportation/shipping purposes (for US Domestic shipments only – not in bond) only if they are all being sent to the same location in the United States from a US location. If combined, each carton must be marked individually with the name of the vessel and the Purchase Order Number, and the onboard department name.

7. For international transportation, all individual items for one vessel must be packed separately from any other vessel for International shipments, and all international shipments must have cartons for each individual vessel separated and loaded on separate pallets. **DO NOT COMBINE ITEMS FOR DIFFERENT VESSELS ON THE SAME PALLET FOR INTERNAYTIONAL SHIPMENTS.** Each carton must be marked individually with the vessel name, PO number, and onboard department name. .

8. **IMPORTANT:** Always address deliveries to the Princess vessel specified on the Purchase Order in care of a shoreside receiving location. Always include the Purchase Order number and department name in the address, as follows: **Example:** “MV Princess Vessel Name”
P.O. # XXXXXXXX/DEPT. Name
c/o “Address as per Purchase Order”

9. **IMPORTANT:** Always include the Princess Purchase Order number and name of the shipboard department on the inside and outside of each box, and on all the paperwork.

10. Distributors, Wholesalers, Chandlers and all other suppliers who receive Princess Purchase Orders are required to provide all shipping terms and instructions on the Princess Purchase Order and in this information guide to each manufacturer, sub-contractor, producer or other supplier with whom they arrange delivery to “Ship to” locations specified in Princess Purchase orders.

B. Marking and Labeling Standards:

Mark all shipments for the appropriate destination as provided on the Princess Purchase Order as per the following samples:

SAMPLE

M.V. (Name of ship)

Purchase Order Number & Dept Name (example: P.O. # XXXXXXXXX/DEPT. NAME)

c/o Princess Receiving Location as per PO

OR

The address provided on the Purchase Order. Princess uses many distribution centers to forward material around the world. ENSURE that the shipment is sent to the location specified on the Purchase Order.

Note: It is **MANDATORY** that the **name of the Princess vessel appears on the first line of the address**, regardless of location or the c/o address where the item is being delivered. Always include the name of the Princess vessel on the first line of the ship to address.

C. SAMPLES OF LABELING METHODS

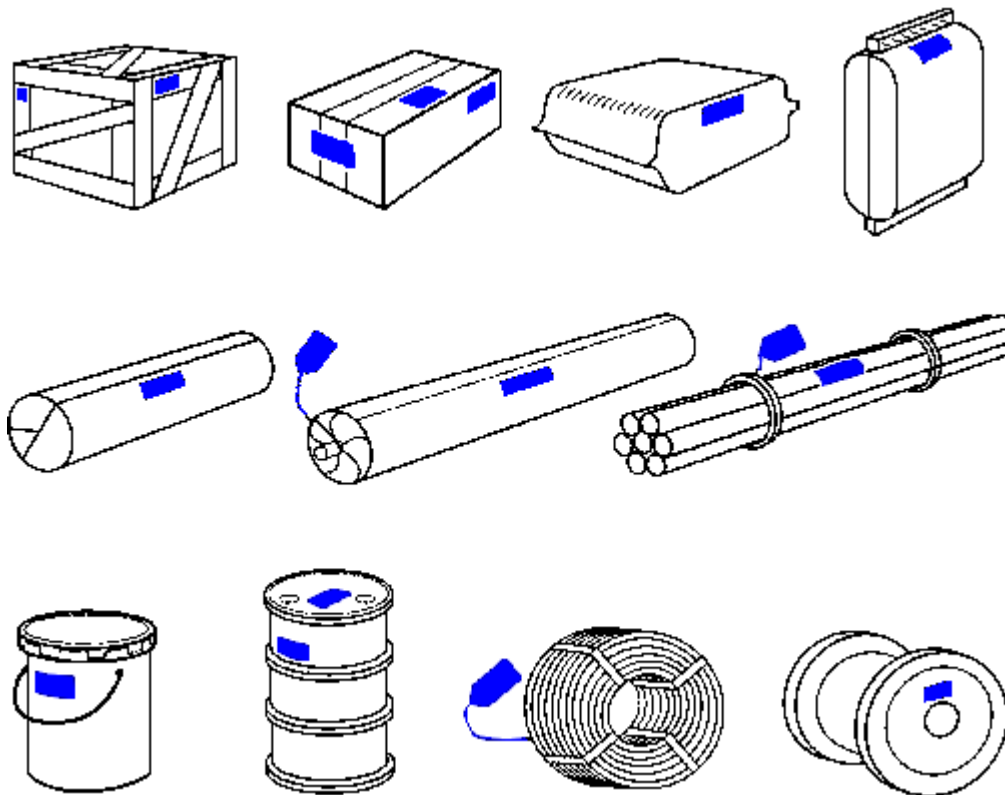

D. Packing Standards – Labeling Cartons

Each carton shipped separately or on a pallet must include on the **OUTSIDE** of each carton:

- ❑ Purchase Order Number and Shipboard Department Name
- ❑ Vessel Name
- ❑ Any required hazardous labels
- ❑ Carton count for each Purchase Order (example: Box 1 of 3, Box 2 of 3, etc.)
- ❑ Any required MSDS sheets for each hazardous item in a plastic envelope attached to carton if shipped separately, or attached to the pallet if cartons are palletized
- ❑ Packing list for each carton in a plastic envelope attached to the carton
- ❑ Commercial invoice for all items in the carton for use with Customs clearance in a plastic envelope attached to the carton if shipped separately, or attached to the pallet if cartons are palletized

Include on the **INSIDE** of each carton:

- ❖ Purchase Order Number and Shipboard Department Name
- ❖ Vessel Name
- ❖ Any required MSDS sheets
- ❖ Packing list with complete listing of items

Packing Lists must include:

Princess Vessel Name

Princess Purchase Order number and Shipboard Department Name

Complete description & quantity of items included

Number of cartons included in the packing list

E. Packing Standards – Material on Pallets

When total carton count exceeds 5 or total weight exceeds 150 lbs, all items must be delivered on a standard 48x40 pallet and shrink-wrapped or taped.

Items for each Princess vessel will be palletized separately. **DO NOT COMBINE** cartons for separate Princess vessels on the same pallet.

All Princess orders must be packaged securely, keeping safety in mind, and in proper shipping containers acceptable for air freight carriers regardless of the transportation mode requested.

Hazardous Materials: Because Princess material may be placed on commercial passenger aircraft, all requirements for Hazardous Materials packaging, labeling and documentation must also be strictly followed.

Again, Package All Orders In A Proper Manner Acceptable For Shipping With Commercial Passenger Air Carriers, irregardless of the shipping method or destination specified.

Maximum height of pallet and product will not exceed 5 feet (60 inches) high.

Each pallet will be stacked so that no carton extends beyond the side of the pallet.

Each pallet must be clearly numbered (example: 1 of 3, 2 of 3, etc.)

Each pallet must have a manifest/inventory attached which identifies all the items contained on that pallet with a carton count.

DO NOT INCLUDE PAYMENT INVOICES INSIDE OR ATTACHED TO SHIPPING CARTONS.

Payment invoices should be sent to the Princess billing address separately.

F. Packing Standards – Cartons to be shipped individually

For total carton count of 5 or less, or total combined weight of 150 lbs or less, cartons should be shipped as a consolidated shipment, but need not be palletized.

Items for each Princess vessel will be packed in separate cartons. **DO NOT COMBINE** items for separate Princess vessels in the same carton.

All Princess orders must be packaged securely, keeping safety in mind, and in proper shipping containers acceptable for air freight carriers regardless of the transportation mode requested.

Hazardous Materials: Because our orders may be placed on commercial passenger aircraft, all requirements for Hazardous Materials packaging, labeling and documentation must also be strictly followed. For information regarding shipment of hazardous materials, please refer to the U.S. government web site at: <http://hazmat.dot.gov/>

Again, Package All Orders in a Proper Manner Acceptable for Shipping with Commercial Passenger Aircraft Carriers, irregardless of the shipping method or destination specified.

Include on the **OUTSIDE** of each carton:

- ❑ Purchase Order Number and Shipboard Department Name
- ❑ Vessel Name
- ❑ Any required hazardous labels
- ❑ Carton count for each Purchase Order (example: Box 1 of 3, Box 2 of 3, etc.)
- ❑ Any required MSDS sheets for each hazardous item in a plastic envelope attached to carton if shipped separately, or attached to the pallet if cartons are palletized. MSDS must contain emergency contact information for the materials as shipped and any related hazardous class and U.N. numbers.
- ❑ Packing list for each carton in a plastic envelope attached to the carton
- ❑ Commercial invoice for all items in the carton for use with Customs clearance in a plastic envelope attached to the carton if shipped separately, or attached to the pallet if cartons are palletized

Include on the **INSIDE** of each carton:

- ❖ Purchase Order Number and Shipboard Department Name
- ❖ Vessel Name
- ❖ Any required MSDS sheets
- ❖ Packing list with complete listing of items

Packing Lists must include:

Princess Vessel Name

Princess Purchase Order number and Shipboard Department Name

Complete description & quantity of items included

Number of cartons included in the packing list

G. Bill of Lading (BOL)/Air Way Bill (AWB) Preparation:

In the past, the Princess has asked suppliers to just indicate “Ship’s supplies in transit – NO Duty Applicable” on the Airway Bills and Bills of Lading as adequate description for shipment. Given the new global security concerns and Customs enforcement priorities, that simple description is no longer adequate.

Bills of Lading (BOLs) and Airway Bills (AWBs) are required to move material both domestically and internationally. Shippers are required to complete the BOL/AWB prior to shipping. Since many Princess purchased items are exported, imported, or moved internationally during their transit to Princess vessels, AWB/BOLs need to be complete and accurate for international shipments.

Princess requirements in this regard are:

Product Description:

1st Line: The first line of the product description should read: “Ship’s supplies in transit – NO duty applicable”.

2nd Line: The second and subsequent lines **MUST list every item being shipped by describing their nomenclature and quantity.**

Last Line: The final line of the description should read: “Ship’s supplies in transit – NO Duty Applicable”

REMEMBER: Each BOL or AWB **MUST contain an accurate description of the material being shipped. The phrase “Ship’s supplies in transit – NO Duty Applicable” -- by itself -- is NOT adequate description.**

That phrase must be used in conjunction with a full and complete description of the items being shipped.

H. Commercial Invoice Preparation:

For every items purchased, there is a possibility that the product may be exported to meet a Princess vessel in a remote port of call. Therefore, every purchase needs to have a “Commercial Invoice” included with the purchased items for Customs declaration purposes. The Commercial Invoice must be created by the supplier, and needs to contain an accurate description of each item and value for Customs purposes. Below is the Guidance that U.S. Customs has provided regarding descriptions of items for international shipping and Customs clearance:

“Customs regulations require a precise narrative description of the cargo.

A precise narrative description is a description that is precise enough for Customs to be able to identify the shapes, physical characteristics, and likely packaging of the manifested cargo so that Customs can identify any anomalies in the cargo when a shipment/container is run through imaging equipment. How specific that information must be depends on the nature of the commodity. For example, "electronics" is not a precise description, but "CD players" or "computer monitors" would be.

To be clear, IN NO CASE is a blank description, “freight all kinds” (FAK), “said to contain” (STC) with or without other description, “general merchandise”, “26 pallets”, “various retail merchandise”, “consolidated cargo” or other similarly vague descriptions acceptable.

The following terms are meant to be used as a guide. They are illustrative, not exhaustive, examples of acceptable and unacceptable descriptions. Phrases or words in parenthesis are meant as examples.”

Not Acceptable	Acceptable
Apparel Wearing Apparel Ladies' Apparel Men's Apparel	Clothing Shoes Footwear Jewelry (may include watches)
Appliances	Kitchen Appliances Industrial Appliances Heat Pump
Autoparts Parts	New Autoparts Used Autoparts
Caps	Baseball Caps Blasting Caps Bottle Caps Hub Caps
Chemicals, hazardous Chemicals, non-hazardous	Actual Chemical Name (not brand name) Or U.N. HAZMAT Code Identifier #
Electronic Goods Electronics	Computers Consumer Electronics, Telephones Electronic Toys (can include Gameboys, Game Cubes, Dancing Elmo Doll etc.) Personal/Household Electronics (i.e. PDA's, VCR's, TV's)
Equipment	Industrial Equipment, Oil Well Equipment Automotive Equipment, Poultry Equipment etc.
Flooring	Wood Flooring, Plastic Flooring, Carpet, Ceramic Tile, Marble Flooring
Foodstuffs	Oranges Fish Packaged Rice, Packaged Grain, Bulk Grain
Iron	Iron Pipes, Steel Pipes
Steel	Iron Building Material, Steel Building Material
Leather Articles	Saddles Leather Handbags Leather Jackets, Shoes
Machinery	Metal Working Machinery Cigarette Making Machinery
Machines	Sewing Machines Printing Machines
Pipes	Plastic Pipes PVC Pipes Steel Pipes Copper Pipes
Plastic Goods	Plastic Kitchenware, Plastic Houseware, Industrial Plastics Toys, New/Used Auto Parts
Polyurethane	Polyurethane Threads Polyurethane Medical Gloves
	Personal Effects Household Goods

Not Acceptable	Acceptable
Rubber Articles	Rubber Hoses Tires Toys Rubber Conveyor Belts
Rods	Welding Rods Rebar Aluminum Rods Reactor Rods
Scrap	Plastic Scrap Aluminum Scrap Iron Scrap
STC (Said to Contain) General Cargo FAK (Freight of All Kinds) "No Description"	
Tiles	Ceramic Tiles Marble Tiles
Tools	Hand Tools Power Tools Industrial Tools
Wires	Electric Wires Auto Harness Coiled Wire (Industrial)

H. Hazardous Material

The Princess preference for shipment of hazardous material is that the entire shipment from origin to final destination delivery to the Princess vessel is handled by the supplier of the material. Most Princess contracts and purchase orders will specify this. Princess expects the material packaging, labeling, documentation and certification of material shipped by the supplier to comply with all applicable laws and regulations. Every item sent to Princess MUST be accompanied by a Material Safety Data Sheet (MSDS) on the outside and the inside of the packaging.

For Princess purchased hazardous material where delivery is specified in the PO as a Princess consolidation location, the following applies:

1. All hazardous material should be presumed to be forwarded by commercial aircraft, and therefore must be packaged by the supplier to meet current standards for international air shipment of the product that is being supplied.
2. All hazardous material MUST be accompanied by a current copy of the MSDS applicable to that product. Each container of material (carton, pack, box, etc.) MUST contain a current copy of the applicable MSDS on the outside of the container as well as on the inside of the container (where practical).
3. A copy of each MSDS for each item supplied MUST accompany all documentation provided to the Princess or it's agents for shipping, in addition to the copies of the MSDS provided on the inside and outside of the container.
4. All hazardous material and its container must be correctly labeled by the supplier in accordance with current laws and regulations.
5. All hazardous material delivered to the Princess or tendered to it's agents for transportation must be accompanied by a commercial invoice that meets the requirements described above in section 2.G.

6. All hazardous material delivered to the Princess or tendered to it's agent for transportation must be segregated from all other non-hazardous material on separate pallets containing only the hazardous material. **HAZARDOUS MATERIAL MUST NEVER BE COMBINED WITH NON-HAZARDOUS ITEMS IN THE SAME CARTON OR ON THE SAME PALLET.**
7. Questions regarding hazardous material packaging, labeling, documentation, or other Princess Logistics requirements should be directed to the Princess Buyer for clarification. When in doubt, ask the Princess Buyer who issued the Purchase order for the material to clarify any Princess requirements prior to transporting hazardous items or shipping them to the Princess or its vessels.

J. Delivery of Shipping Documentation

Since every Princess purchase is eligible to be exported outside the country of origin or country of purchase, it is essential for rapid delivery that all required documents to support export/import/international shipping be supplied by the supplier to the Princess designated "Ship to" location contained on the Purchase Order. Supplier must fax or courier all required shipping documents for the products they supply pursuant to a Princess purchase Order to the "ship to" location provided on the Princess Purchase Order. Required documents will vary by country and commodity, but usually include Commercial Invoice, MSDS Sheet (for hazardous material), Bill Of Lading (BOL or AWB), any required certificates of origin, content, inspection, etc. applicable to specific commodities, and certificates or proof of compliance with all laws applicable to specific commodities. Questions regarding this should be addressed to the Princess Buyer for clarification or instructions.

Section 3: "Ship to" Locations

A. Consolidation Centers

Generally, Princess Purchase Orders will specify that purchased items to be shipped to a consolidation center whose address is listed on the front of the Purchase Order. These specific shipping address and instructions will be provided on the Purchase Order. Be sure to follow the instructions on the Purchase Order. Delivery terms and addresses will be specified in the Purchase Order.

This is NOT a complete list, but serves as an **example of a consolidation location format** used by Princess. **Be sure to use the "ship to" location on the purchase order:**

EXAMPLES

PRINCESS DETAILS

MV (ship name)
 Purchase Order Number (PO number)/ (department name)
 c/o Princess Distribution Center

EXAMPLE Address:

MV Vessel Name
PO# XXXXXXXX/DEPT. Name
c/o Princess Address

B. SHIPMENTS TO LOCATIONS OTHER THAN CONSOLIDATION CENTERS

If you are instructed by the Purchase Order to ship to a **specific port location**, and you need an address or additional information or guidance on how to do this, please contact **The Buyer first**. If you are instructed by the Purchase Order to ship to an **international location** that requires a U.S. Customs entry or clearance or other governmental agency clearance, please contact **The Buyer first**.

Always seek additional information from the Buyer. This contact information is included in the Purchase Order.

Billing Address

All invoices for Purchase Orders with P.O. numbers should be mailed to:

Princess
Attn: (Dept Name) (Buyer's name)
P.O. Box 959
Santa Clarita, Ca. 91380-9059

All invoices for purchases that DO NOT Have Purchase Order Numbers should be mailed to:

Princess
Attn: (Dept name) (Buyer's name)
P.O. Box 966
Santa Clarita, Ca. 91380-9066